

WINDSTER™

www.windsterhood.com

User's Manual

**UNDER CABINET SERIES
WALL MOUNT SERIES**

**RA-35U30SS/RA-35W30SS
RA-35U36SS/RA-35W36SS
RA-35U42SS/RA-35W42SS
RA-35U48SS/RA-35W48SS**

NOTE: PLEASE INSPECT HOOD IMMEDIATELY UPON RECEIVING. CLAIM OF DAMAGE AFTER 7 DAYS OF DELIVERY WILL BE DENIED.

This unit is designed for indoor residential use only. DO NOT USE OVER A WOOD GRILL OR MOUNT IN OUTDOOR ENVIRONMENT.



Please read this operation manual thoroughly before using your range hood. Store it in a safe location for when you need to reference it in the future.

Table of Contents

<i>Safety Information</i>	2 – 3
<i>Content Checklist</i>	4
<i>Measurements</i>	5
<i>Preparation</i>	6– 7
<i>Installation</i>	8 – 9
<i>Installation Diagram</i>	10
<i>Operation & Features</i>	11 – 12
<i>Cleaning & Maintenance</i>	13
<i>Troubleshooting</i>	14
<i>Part List / Replacement</i>	15 – 16
<i>Warranty / Contact Us</i>	17 – 18

SAFETY INFORMATION**TO REDUCE THE RISK OF A FIRE, ELECTRICAL SHOCK, AND/OR INJURY OBSERVE THE FOLLOWING:**

- Unit is intended for indoor residential use only. If you should have questions, contact the manufacturer at the address or telephone number listed in the warranty.
- In case the unit should need to be cleaned or repaired, switch power off at service panel and lock service disconnecting means to prevent power from being switched on accidentally. When the service disconnecting means cannot be locked, securely fasten a prominent warning device, such as a tag, to the service panel.
- Installation work and electrical wiring must be done by a qualified technician in accordance with all applicable codes and standards, including fire-rated construction.
- Sufficient air is needed for proper combustion and exhausting of gases through the flue (chimney) of fuel burning equipment to prevent back drafting. Follow the heating equipment manufacturer's guideline and safety standards such as those published by the National Fire Protection Association (NFPA), and the American Society of Heating, Refrigeration and Air Conditioning Engineers (ASHRAE), and the local code authorities.
- Because the unit is made of stainless steel, it may contain sharp edges. Be careful to avoid cuts and abrasions by wearing protective gloves during installation and cleaning.
- Before you begin to cut or drill into the wall, verify that there is no electrical wiring or any other hidden electrical components.
- Ducted fans must always be vented to the outdoors.
- The unit must be properly grounded and installed at the recommended height before beginning operation.
- To reduce the risk of fire, use only metal ductwork.

**CAUTION: FOR GENERAL VENTILATING USE ONLY. DO NOT USE TO EXHAUST HAZARDOUS OR EXPLOSIVE MATERIALS AND VAPORS**



TO REDUCE THE RISK OF FIRE, OR ELECTRIC SHOCK, DO NOT USE THIS FAN WITH ANY SOLID-STATE SPEED CONTROL DEVICE.

- Regardless of heat level, never leave any surface materials unattended while operating an open flame.
- Always turn hood ON when cooking at high heat or when flambéing food (i.e. Crepes Suzette, Cherries Jubilee, Peppercorn Beef Flambé).
- Depending on amount of usage, clean ventilating fans and filters frequently. Grease should not be allowed to accumulate on fan or filter. For instructions on the how to clean, see maintenance page.
- Never leave surface units unattended at high settings. Boil-overs may cause smoking and greasy spillovers may ignite as result. Heat oils slowly on low or medium settings.
- Use proper pan size. Always use cookware appropriate for the size of the surface element.



TO REDUCE THE RISK OF INJURY TO PERSONS IN THE EVENT OF A RANGE TOP GREASE FIRE, OBSERVE THE FOLLOWING:

- SMOTHER FLAMES with a close-fitting lid, cookie sheet, or metal tray, then turn off the burner. BE CAREFUL TO PREVENT BURNS. If the flames do not go out immediately, EVACUATE AND CALL 911.
- NEVER PICK UP A FLAMING PAN —Doing so may result in serious burns and possibly spread the fire.
- DO NOT USE WATER – Grease fire must be extinguished before further action may be taken. Using water will agitate the grease and may cause a violent steam explosion.
- Use a Fire Extinguisher ONLY if:
 - ❖ You know you have a Class ABC extinguisher, and you already know how to operate it.
 - ❖ The fire is small and contained in the area where it started.
 - ❖ The fire department is being called.
 - ❖ You are able to safely control the fire with your back to an open exit. *

Based on "Kitchen Fire safety Tips" published by NFPA.

CONTENT CHECKLIST**1. CONTENTS INCLUDED**

- a. (1) RA-35 series(30", 36" 42" or 48")hood assembly
 - i. U = Under mount (DUCT COVER NOT INCLUDED)
 - ii. W = Wall mount (DUCT COVER INCLUDED)
 - Ex. RA35U30SS = under cabinet mount
 - Ex. RA35W30SS = wall mount
- b. (1) User's manual
- c. (1) Black square to 8" round transition collar
- d. (2) Baffle filters w/ handles (30" model only)
- e. (2) Baffle filters w/ handles & (1) stainless steel filler (36" model only)
- f. (2) Baffle filters w/ handles & (2) stainless steel filler (42" model only)
- g. (3) Baffle filters w/ handles & (2) stainless steel filler (48" model only)
- h. (1) Oil tray
- i. (1) Screw packet

2. CONTENTS NOT INCLUDED

- a. RA35CFMR (CFM reducer)
- b. Heat Lamps (250w, 120v, BR40)
- c. 8" Aluminum or metal piping

3. TOOLS REQUIRED (NOT INCLUDED)

- a. Safety gloves
- b. Safety glasses
- c. Electric drill w/ starter bit
- d. Utility knife
- e. Spirit level
- f. Measuring tape
- g. Writing instrument (pen, marker, pencil)
- h. Aluminum tape

MEASUREMENTS **5**

Fig. 1a

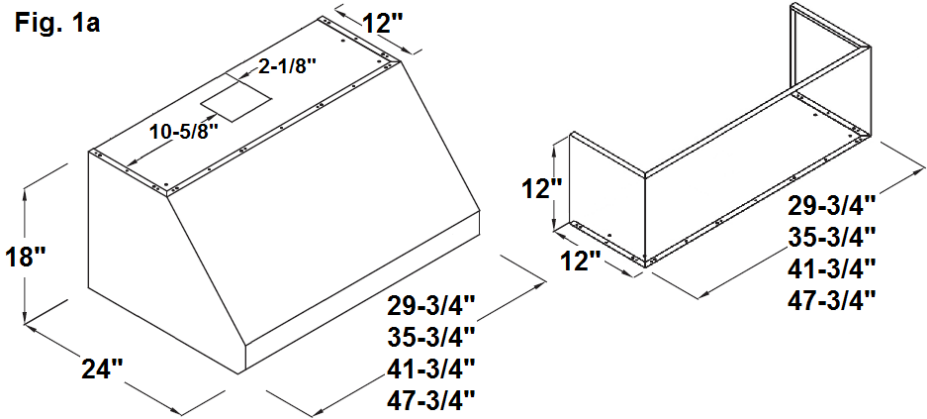

Mounting keyhole measurements are located at 3-1/2" and 10-1/2" from the back of unit and 1" and 2-1/4" from both sides

Fig. 1b

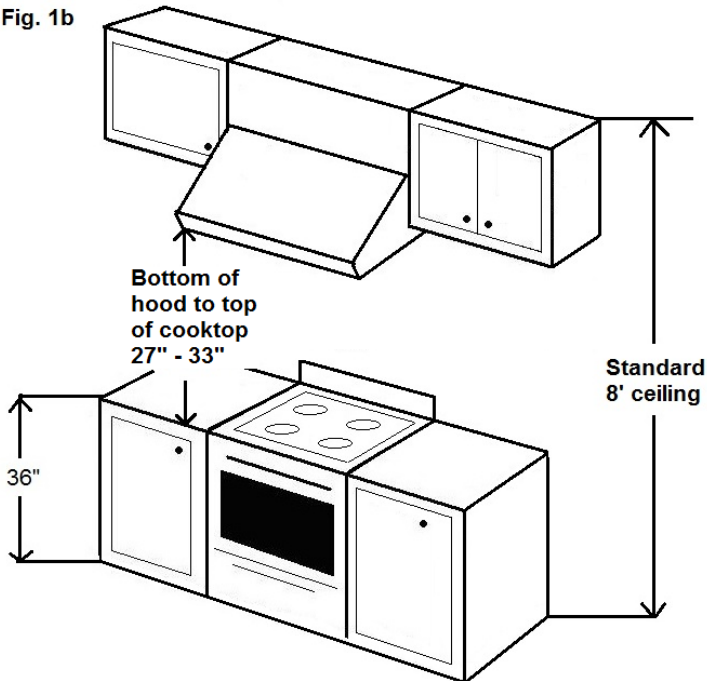

6

PREPARATION

PREPARATION

1. BEFORE YOU START

****DO NOT INSTALL IF DAMAGED****

****RETURN OR EXCHANGE WILL BE DENIED IF INSTALLED****

- a. Be sure you have all the content of your purchase and required tools for this installation.
- b. Installation may take at least 2 to 3 hours from start to finish.
- c. Plan to use as few elbows or turns as possible for more efficient air flow.
- d. Collar size may need to be increased if utilizing a long duct run.
- e. At least 12" of vertical duct is required before any turn.
- f. Do not try to install this unit by yourself, **SERIOUS INJURY MAY OCCUR.**
- g. At least two people are needed for installation.
- h. Hiring a certified installer and electrician is recommended.
- i. Cold weather installation will require make-up air or a CFM reducer.

Check with your local building codes for more detail.

2. LOCATION

- a. Determine the exact location you wherewant to install the range hood.
- b. Distance between cooktop and range hood should be between 27"-33".
- c. Range hood should be mounted at stated measurements to ensure performance and lifespan of electrical components.
- d. Correctly measure the dimension needed to install the unit.

Use Fig. 1a and 1bon page 5 for measurements

Fig. 1c - Cabinet

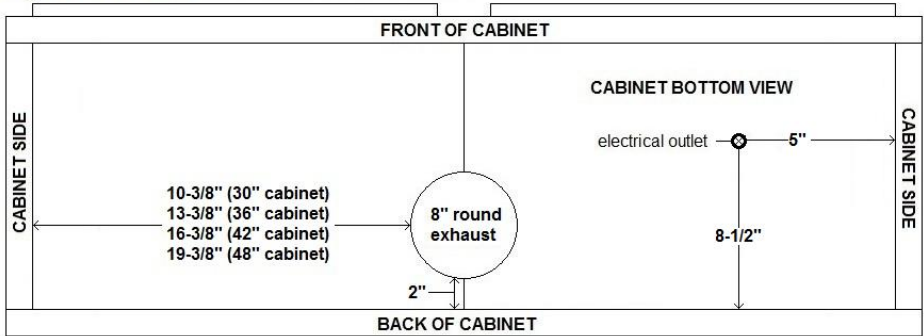

- e. For cabinet with recessed-bottom, use (2) 3" x 12" or 15" wood strips on both sides to balance the recession. Use (4) 1-1/4" long flat head screws to secure the wood strips to cabinet. (Fig. 1d)

Fig. 1d - Cabinet w/ recessed-bottom

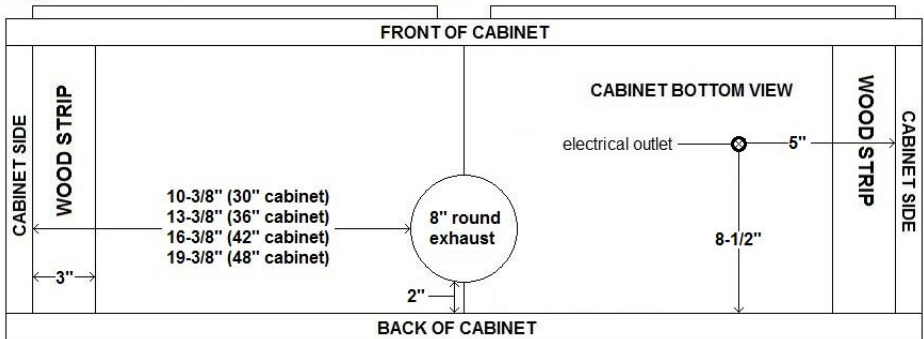

3. HOOD

- a. Inspect for any sign of defect or damage. (ie. scratches, dents, loose seams, etc.)
- b. Power up the unit to make sure it is working properly.
- c. Remove the protective file on the baffle filters and fillers.
- d. Install baffle handles to filters using a Philips screwdriver.

INSTALLATION

1. UNDER CABINET INSTALLATION

- a. Make sure all preparation steps are completed.
- b. Feed the wires coming out of the hood through the bottom of the cabinet.
- c. Lift the unit up flush against the wall and the bottom of the cabinet.
- d. Using the screws and washers provided, insert into each of the keyhole openings and tightly secure the unit against the bottom of the cabinet.

NOTE: Install more screws through the back of the unit if necessary.

- e. Use the conversion collar for 8" ducting.
- f. Connect an 8" ducting to the collar of the hood.
- g. Finish off by sealing the connection point with aluminum tape.

2. WALL MOUNT INSTALLATION (OPTIONAL)

- a. Optional RA35DC duct cover is required for wall mount installation.
- b. Inspect the RA35DC for any sign of defect or damage. (ie. scratches, dents, loose seams, etc.)
- c. Be sure you have the following content.
 - i. One piece stainless steel duct cover
 - ii. Screw packet
- d. Determine the exact location you want to install the range hood.
- e. Prepare back wall frame with cross wood support.
- f. Install the hood mounting bracket to the back of the unit and secure it with the (12) screws provided. (6 screws for each bracket) **(Fig. 2a)**
- g. Mount the unit onto wall with mounting screws (not included) **(Fig. 2b)**
- h. Use a spirit level to ensure the balance of the hood is true.
- i. Install the exhaust piping and connect it to the outlet of the unit. **(Fig. 2c)**
- j. Place the duct cover on top of the unit and secure it with the (7) duct cover screws provided. **(Fig. 2d)**

3. COLD WEATHER INSTALLATION (OPTIONAL)

- a. Check with your local building codes to see if a CFM reducer is an acceptable alternative to make-up air.
- b. Remove the RA35CFMR (CFM Reducer) and inspect for any sign of defect or damage. (ie. Cracks, broken flips)
- c. **For UNDER CABINET installation: COMPLETE Step A – D of Section 1 UNDER CABINET INSTALLATION THEN GO TO STEP E BELOW.**
- d. **For WALL MOUNT installation: COMPLETE Step A – H of Section 2 WALL MOUNT INSTALLATION THEN GO TO STEP E BELOW.**
- e. Place the CFM reducer onto the outlet of the unit and seal the connection point with aluminum tape. (Be sure it is secure with no opening or gaps)
- f. Connect an 8" ducting to the collar of the CFM reducer.
- g. Finish off by sealing the connection point with aluminum tape.

Installation diagram available on next page

10 INSTALLATION DIAGRAM

INSTALLATION DIAGRAM

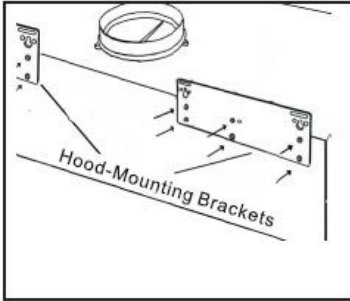

Fig. 2a

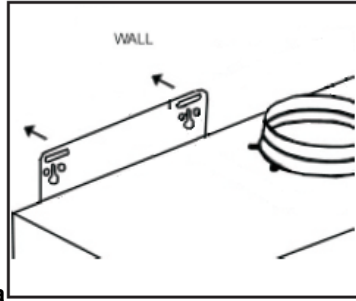

Fig. 2b

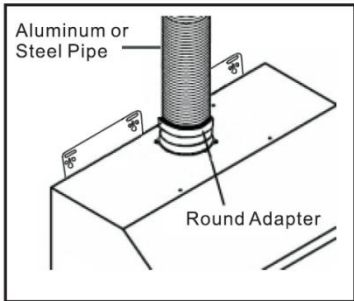

Fig. 2c

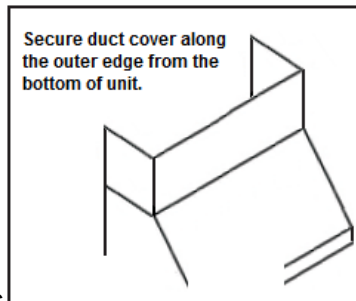

Fig. 2d

OPERATION & FEATURES

1. EASY ACCESS CONTROL SWITCH (from left to right)

- a. Button 1 – ON / DELAY SHUTOFF / OFF
- b. Button 2 –Light control
- c. Button 3 – Speed control
- d. Blue color speed indicator

2. HEAT LAMP LIGHTING

- a. (2) 250w heat lamp (NOT INCLUDED)

3. BAFFLE FILTERS

- a. (2) 14-3/4" x 11" baffle filters (30" model only)
- b. (2) 14-3/4" x 11" baffle filters and (1) fillers(36" model only)
- c. (2) 14-3/4" x 11" baffle filters and (2) fillers (42" model only)
- d. (3) 14-3/4" x 11" baffle filters and (2) fillers (48" model only)

4. PUTTING IN THE OIL TRAY AND BAFFLE FILTERS

- a. Insert the oil tray into the unit at an angle and slide it down at the slot located next to the heat lamp sockets. (Fig. 3a)

Fig. 3a

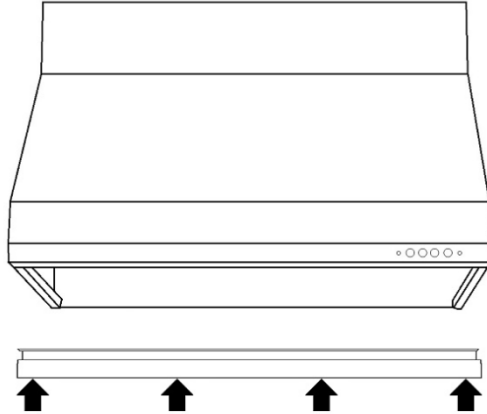

- b. ① Slide the baffle filter into the hood.
② Push the baffle filter upward.

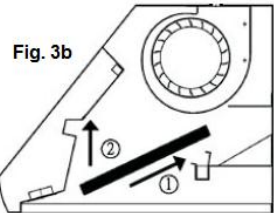

- c. ③ Slide the baffle filter toward you.
④ Pull the end of the baffle filter downward.

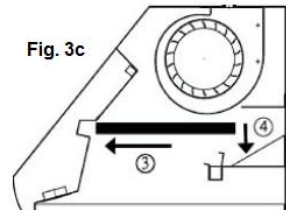

- d. ⑤ Fit into place.

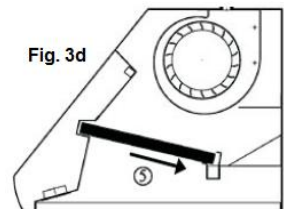

CLEANING & MAINTENANCE

WARNING!!!



To prevent the possibility of a fire and explosion, do not use flammable liquids or solvents to clean the unit or any of its parts.



Check to make sure all power sources are disconnected before servicing or taking unit apart for cleaning.



Please thoroughly clean the unit weekly as stainless steel can rust under certain condition or by improper cleaning.

1. RANGE HOOD

- a. Use household cleaner to remove grease or dirt from the outer shell of the unit. Spray on wiping cloth or sponge and wipe in the direction of the grain to avoid scratching the unit. (DO NOT SPRAY DIRECTLY ONTO UNIT)
- b. Clean the inner working of the unit periodically to avoid grease build-up.
- c. Do not open control switch panel while the hood is connected to power.
- d. Use stainless steel cleaner to bring back the luster of the unit.

2. BAFFLE FILTERS

- a. Remove baffle filters from unit and place in warm soapy water.
- b. Clean the baffle filters regularly to maintain efficient suction power.
- c. Do not drop baffle filters or fillers.
- d. Let it soak thoroughly and then clean it with a wiping cloth or sponge.
- e. Baffle filters may also be cleaned using residential dishwasher.

TROUBLESHOOTING**WARNING!!!**

Check to make sure all power sources are disconnected before starting any troubleshooting. Safety gloves and glasses should be worn when working on the unit. Serious injury or death may occur if safety precautions are not followed.

RA35 Series	
Light Issue (All not turning on)	<ol style="list-style-type: none"> 1. Halogen lights may need to be changed. 2. New Transformer replacement is required.
Halogen/LED light issue	<ol style="list-style-type: none"> 1. Replace burnt 20w light bulb. 2. LED may require new fixture or driver.
Light Issue (One light not turning on)	<ol style="list-style-type: none"> 1. LED light may be defected.
Speed indicator not showing speed levels	<ol style="list-style-type: none"> 1. Complete Control switch replacement is required.
Burnt/melted control switch	<ol style="list-style-type: none"> 1. Complete Control switch replacement is required.
Speed levels not working correctly	<ol style="list-style-type: none"> 1. Check all wiring to and from the unit. 2. Complete control switch replacement is required.
Unit lacking smoke intake	<ol style="list-style-type: none"> 1. Check ducting for foreign object. 2. Ensure the ducting is properly sealed. 3. Clean filters to increase airflow.
Unit showing no power indication	<ol style="list-style-type: none"> 1. Make sure the power source is working properly. 2. All wiring is connected.
Unit making humming noise	<ol style="list-style-type: none"> 1. Replace defective capacitor with new one.

PART LIST / REPLACEMENT

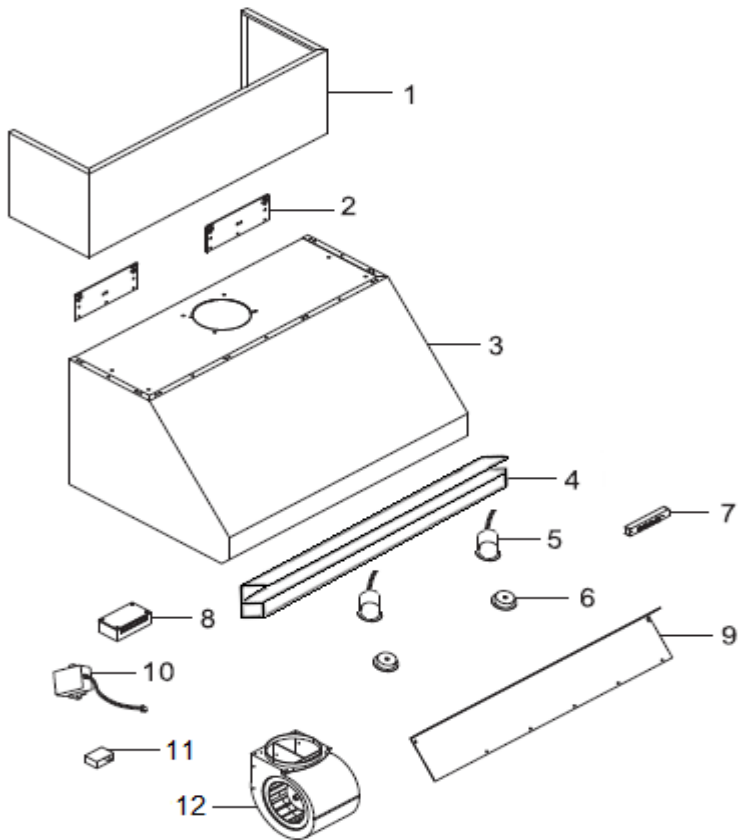

BAFFLE FILTERS

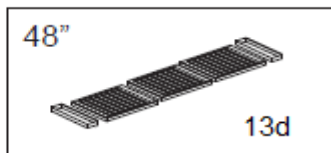
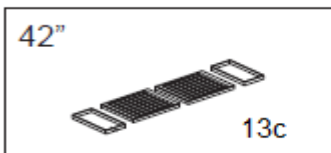
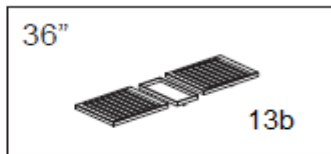

16 PART LIST / REPLACEMENT

#	Description	#	Description
1	Duct cover (optional)	9	Support panel
2	Hood bracket (optional)	10	Transformer
3	Hood body assembly	11	Capacitor
4	Oil tray bar	12	Squirrel cage motor x 2
5	Heat lamp light socket	13a	(2) baffle filters (30" model)
6	LED lights	13b	(2) baffle filters / (3) fillers (36" model)
7	Control switch	13c	(2) baffle filters / (3) fillers (42" model)
8	Control board	13d	(3) baffle filters / (2) fillers (48" model)

WARRANTY / CONTACT US

LIMITED WARRANTY

Windster Hoods Inc. warrants its product against defects in material or workmanship as follows:

Labor:For a period of one (1) year from the date of purchase, if the product is determined to be defective, Windster will attempt to repair the product, at its option, at no charge. After the warranty period, customer must pay for all labor charges. During the "labor" warranty period there will be no charge for any work done on the purchased model. (All labor repairs are limited only to the installation of electrical components.)

Parts:In addition, Windster will supply, at no charge, new or rebuilt replacements in exchange for defective parts for a period of two (2) years. After the warranty period, you must pay for all parts costs. During the "parts" warranty period, there will be no charge for parts

You must provide the serial number of your unit for any replacement parts during the warranty period. This warranty applies to products purchased and serviced in the United States only.

For products purchased in Canada, please contact your local retailer where you purchased the unit for service.

* Windster Hoods, Inc. will attempt to repair malfunctioning units prior to shipping a replacement. In the case that a unit cannot be repaired and must be replaced, Windster Hoods, Inc. will not be held liable for removal/installation fees of the malfunctioning/replacement unit.

WHAT IS NOT COVERED BY MANUFACTURE WARRANTY

1. Damages resulting from any of the following:
 - a. Improper installation or maintenance
 - b. Any repair, modification, alteration or adjustment not authorized by the manufacturer or an authorized service dealer
 - c. Misuse and/or accidents
 - d. Incorrect electric current, voltage or power supply
 - e. Improper setting of any control (Pressing multiple selections at the same time)
 - f. Improper chemical cleaning (commercial or industrial cleaning agents)
2. Products purchased for use in a commercial or industrial setting (such as in a hotel, office, restaurant, or other business)
3. Damage resulting from natural disasters (earthquake, flood, storm, etc.)
4. Aluminum Filters, Baffle Filters, Charcoal Filters, and Oil Cup Filters
5. Light Bulbs

CONTACT US

Windster Hoods, Inc.

Toll Free: (877) 350 – 5215

www.windsterhood.com

Information subject to change without notice